

Lydspor  
Trumpet in B $\flat$

# MUSIC FOR A HOUSE

Svend Hvidtfelt Nielsen  
Ny start 1/3/11

$\text{♩} = 90$   
Dørsmæk  
0.1" 2.7" 10.7" 13.4" 16.0" 18.7"  
Dørsmæk + dybt C  
3 3 3

Staff 1: Measures 1-5. Measure 1: 0.1" Dørsmæk. Measure 2: 2.7". Measure 3: 10.7" Dørsmæk. Measure 4: 13.4". Measure 5: 16.0" Dørsmæk + dybt C. Measure 6: 18.7". Dynamics: 3, 3, 3.

26.7" 29.4" 37.4" 40.0" 45.4" 48.0"  
11 Dørsmæk + dybt C  
3 2

Staff 2: Measures 6-11. Measure 6: 26.7". Measure 7: 29.4". Measure 8: 37.4" Dørsmæk + dybt C. Measure 9: 40.0". Measure 10: 45.4". Measure 11: 48.0". Dynamics: 3, 2.

50.7" 53.4" 56.0" 58.7" 1'01.4" 1'04.0"  
20 2

Staff 3: Measures 12-17. Measure 12: 50.7". Measure 13: 53.4". Measure 14: 56.0". Measure 15: 58.7". Measure 16: 1'01.4". Measure 17: 1'04.0". Dynamics: 2.

1'09.4" 1'12.0" 1'14.7"  
27 Dørekko Tskk Dørekko

Staff 4: Measures 18-20. Measure 18: 1'09.4" Dørekko. Measure 19: 1'12.0" Tskk. Measure 20: 1'14.7" Dørekko.

1'17.4" 1'20.0" 1'22.7" 1'25.4"  
30 Tskk etc. Dumplyd

Staff 5: Measures 21-24. Measure 21: 1'17.4" Tskk. Measure 22: 1'20.0" etc. Measure 23: 1'22.7". Measure 24: 1'25.4". Dynamics: Dumplyd.

1'28.0" 1'30.7" 1'33.4" 1'36.0" 1'38.7" 1'41.4"  
34

Staff 6: Measures 25-30. Measure 25: 1'28.0". Measure 26: 1'30.7". Measure 27: 1'33.4". Measure 28: 1'36.0". Measure 29: 1'38.7". Measure 30: 1'41.4".

1'44.0" 1'46.7" 1'49.4" 1'52.0" 1'54.7"  
40 Distorted pno Distorted pno trinpåtrappe

Staff 7: Measures 31-35. Measure 31: 1'44.0" Distorted pno. Measure 32: 1'46.7". Measure 33: 1'49.4" Distorted pno. Measure 34: 1'52.0". Measure 35: 1'54.7" trinpåtrappe.

1'57.4" 2'00.0" 2'02.7" 2'05.4" 2'08.0"  
45 Distorted pno

Staff 8: Measures 36-40. Measure 36: 1'57.4" Distorted pno. Measure 37: 2'00.0". Measure 38: 2'02.7". Measure 39: 2'05.4". Measure 40: 2'08.0".

2'10.7" 2'13.4" 2'16.0" 2'18.7" 2'21.4"  
50

Staff 9: Measures 41-45. Measure 41: 2'10.7". Measure 42: 2'13.4". Measure 43: 2'16.0". Measure 44: 2'18.7". Measure 45: 2'21.4".

2'24.0" 2'26.7" 2'29.4"  
55

Staff 10: Measures 46-50. Measure 46: 2'24.0". Measure 47: 2'26.7". Measure 48: 2'29.4".

2'32.0" 2'34.7" 2'37.4" 2'40.0"

58

Et dybt C ligger som drone.  
Korindsatser forudgribes  
ofte af et C.

1

2'42.7" 2'45.4" 2'48.0" 2'50.7" 2'53.4"

62

2

2'56.0" 2'58.7" 3'01.4" 3'04.0" 3'06.7" 3'09.4" 3'12.0"

67

3

3'20.0" 3'22.7" 3'28.0" 3'30.7" 3'33.4" 3'36.0"

3

2

mf

2

3'41.4" 3'44.0" 3'46.7" 3'49.4" 3'52.0" 4'05.4"

84

4

5

mf

5

4'08.0" 4'10.7" 4'13.4" 4'16.0" 4'21.4" 4'24.0"

94

rangle

2

4'26.7" 4'29.4" 4'32.0" 4'34.7" 4'37.4"

101 6 Quasistemme

4'40.0" 4'42.7" 4'45.4" 4'48.0" 4'50.7"

106 7

4'53.4" 5'01.4" 5'04.0" 5'06.7" 5'09.4" 5'12.0"

111 8

5'14.7" 5'17.4" 5'20.0" 5'22.7" 5'33.4"

119 4

5'36.0" 5'38.7" 5'41.4" 5'44.0"

127 9

5'46.7" 5'49.4" 5'52.0" 5'54.7"

131

Lydspor, Trumpet in B $\flat$

5'57.4" 6'00.0" 6'02.7" 6'05.4" 6'08.0" 6'10.7" **10** **3**



6'18.7" 6'21.4" 6'32.0" 6'34.7" **11** 6'37.4"

143 **4** **4**



6'40.0" 6'42.7" 6'56.0" **12** 7'17.4"

151 **5** **8** **5** **8** **f**

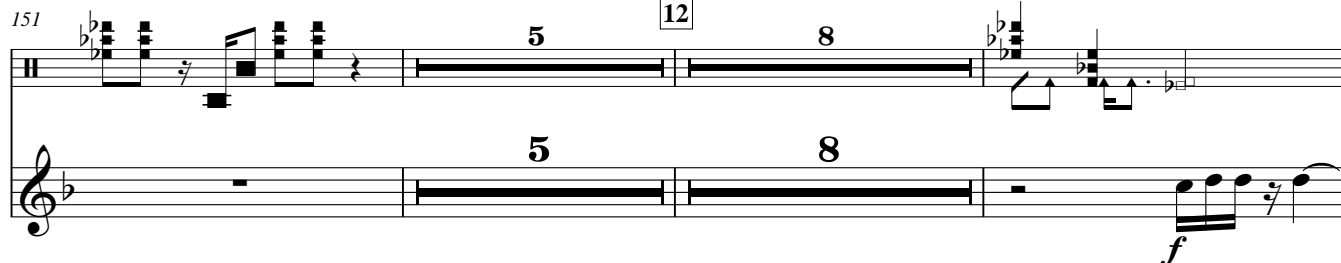

7'20.0" **13** 7'22.7" 7'25.4" 7'28.0" 7'30.7" 7'33.4"

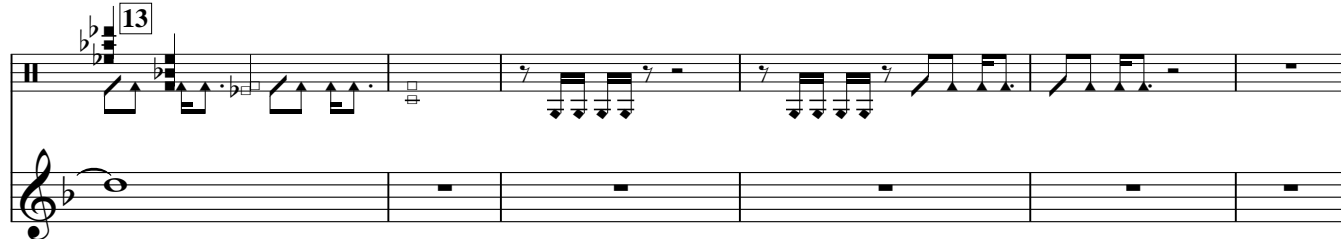

7'36.0" **14** 7'38.7" 7'41.4" 7'44.0" 7'46.7"

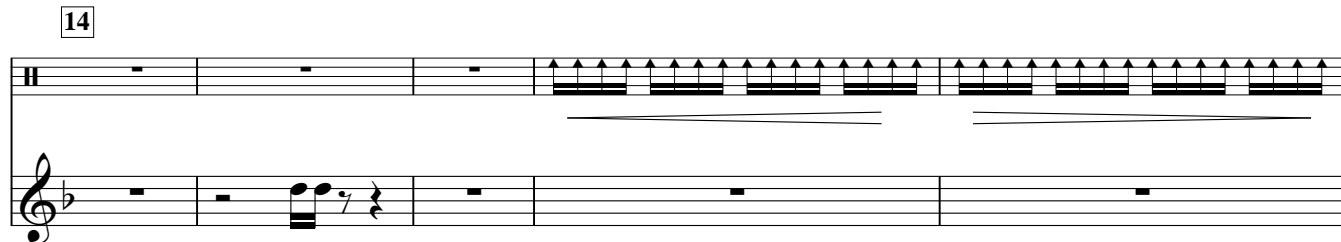

7'49.4" 7'52.0" 7'54.7" 7'57.4" 8'00.0"

177

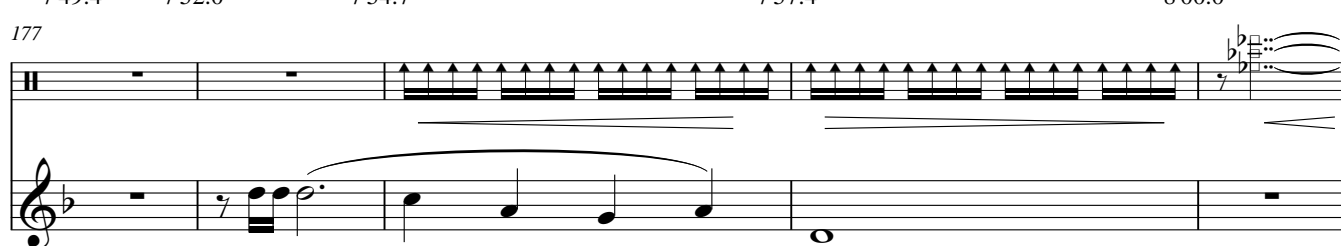

8'02.7" 8'05.4" 8'08.0" 8'10.7"

182 **15**

Musical notation for measures 182-185. The top staff shows a trumpet line with a sequence of eighth notes and rests, starting with a dynamic marking of 'p'. The bottom staff shows a melodic line with a long note in the final measure.

8'13.4" 8'16.0" 8'18.7" 8'21.4" 8'24.0"

186

Musical notation for measures 186-190. The top staff shows a trumpet line with a sequence of eighth notes and rests, starting with a dynamic marking of 'p'. The bottom staff shows a melodic line with a long note in the final measure.

8'26.7" 8'29.4" 8'32.0" 8'34.7" 8'37.4" 8'40.0"

191 **16**

Musical notation for measures 191-195. The top staff shows a trumpet line with a sequence of eighth notes and rests. The bottom staff shows a melodic line with a long note in the final measure.

8'42.7" 8'45.4" 8'48.0" 8'50.7" 8'53.4"

197

Musical notation for measures 197-201. The top staff shows a trumpet line with a sequence of eighth notes and rests. The bottom staff shows a melodic line with a long note in the final measure.

8'56.0" 8'58.7" 9'01.4" 9'04.0"

202 etc. fremover **17**

Musical notation for measures 202-205. The top staff shows a trumpet line with a sequence of eighth notes and rests. The bottom staff shows a melodic line with a long note in the final measure.

9'06.7" 9'20.0" 9'22.7" 9'25.4"

206 **5** **18** **4**

Musical notation for measures 206-209. The top staff shows a trumpet line with a sequence of eighth notes and rests. The bottom staff shows a melodic line with a long note in the final measure.

9'36.0" 9'38.7" 9'41.4" 9'44.0" 9'46.7" 9'49.4"

217

*mf*

9'52.0" 9'54.7" 9'57.4" 10'00.0" 10'02.7" 10'05.4"

19

range

10'08.0" 10'10.7" 10'13.4" 10'16.0" 10'18.7" 10'21.4"

229

range

10'24.0" 10'26.7" 10'29.4" 10'32.0" 10'34.7" 10'37.4"

235

range

10'40.0" 10'42.7" 10'45.4" 10'48.0"

241

range

10'50.7" 10'53.4" 10'56.0" 10'58.7" 11'01.4"

245

range

11'04.0" 11'06.7" 11'09.4"

250

11'12.0" 11'14.7" 11'17.4" 11'20.0" Retrograd 11'22.7" Klaversample

253

11'25.4" 11'28.0" 11'30.7" 11'33.4"

258

11'36.0" 11'38.7" 11'41.4" 11'44.0" 11'46.7"

262

11'49.4" 11'52.0" 11'57.4" 12'00.0" 12'02.7"

23

12'05.4" 12'08.0" 12'10.7" 12'13.4" 12'16.0"

24

3

12'24.0" 12'26.7" 12'29.4" 12'34.7" 12'37.4"

280

12'40.0" 12'42.7" 12'45.4" 12'53.4" 12'56.0"

25

13'01.4" 13'04.0" 13'06.7" 13'09.4" 13'12.0"

294

26

13'20.0" 13'22.7" 13'25.4" 13'28.0" 13'30.7"

301

13'33.4" 13'36.0" 13'38.7" 13'46.7" 13'49.4"

27

13'52.0" 13'54.7" 13'57.4" 14'00.0" 14'02.7" 14'05.4" 14'08.0"

313

28



14'10.7" 14'13.4" 14'16.0" 14'18.7" 14'24.0" 14'26.7" 14'29.4"

320

2 3

14'37.4" 14'40.0" 14'42.7" 14'50.7" 14'53.4"

330

3 3

14'56.0" 15'04.0" 15'06.7" 15'09.4" 15'20.0"

337

3 3 4 4

15'22.7" 15'25.4" 15'36.0" 15'38.7" 15'41.4"

32

33

4 4 3

15'49.4" 15'52.0" 15'54.7" 15'57.4" 16'02.7"

357

2 2

16'05.4" 16'08.0" 16'10.7" 16'13.4" 16'16.0"

34

2 2

16'21.4" 16'24.0" 16'32.0" 16'34.7" 16'37.4" 16'40.0"

35 3 36 3

con sord.

This system contains measures 35 and 36. Measure 35 is marked with a box containing the number 35. Measure 36 is marked with a box containing the number 36. The notation includes a snare drum line and a trumpet line. The trumpet line has a 'con sord.' marking. Both lines feature triplet markings (the number 3) over the notes in measures 35 and 36.

16'48.0" 16'50.7" 16'53.4" 16'56.0" 16'58.7" 17'04.0" 17'06.7"

379 37 2 2

This system contains measures 37 and 38. Measure 37 is marked with a box containing the number 37. The notation includes a snare drum line and a trumpet line. The snare drum line has a '379' marking. Both lines feature a double bar line in measure 37 and a '2' marking over the notes in measure 38.

17'09.4" 17'12.0" 17'22.7" 17'25.4" 17'28.0"

387 38 4 9 9

This system contains measures 38 and 39. Measure 38 is marked with a box containing the number 38. The notation includes a snare drum line and a trumpet line. The snare drum line has a '387' marking. Both lines feature a '4' marking over the notes in measure 38 and a '9' marking over the notes in measure 39.

17'52.0" 17'54.7" 17'57.4" 18'00.0" 18'02.7" 18'05.4"

403 2

This system contains measures 39 and 40. Measure 39 is marked with a box containing the number 39. The notation includes a snare drum line and a trumpet line. The snare drum line has a '403' marking. Both lines feature a '2' marking over the notes in measure 40.

18'10.7" 18'13.4" 18'16.0" 18'18.7" 18'21.4" 18'24.0"

410 39 6 6

This system contains measures 40 and 41. Measure 40 is marked with a box containing the number 39. The notation includes a snare drum line and a trumpet line. Both lines feature a '6' marking over the notes in measure 40 and another '6' marking over the notes in measure 41.

18'40.0" 18'42.7" 18'45.4" 19'01.4" 19'04.0"

421 40 6 3 6 3

This system contains measures 41 and 42. Measure 41 is marked with a box containing the number 40. The notation includes a snare drum line and a trumpet line. Both lines feature a '6' marking over the notes in measure 41 and a '3' marking over the notes in measure 42.

19'12.0" 19'14.7" 19'20.0" 19'22.7"

433

**2** **2** Tskk

19'25.4" 19'28.0" 19'30.7" 19'33.4"

438

**41**

19'36.0" 19'38.7" 19'41.4" 19'44.0"

442

etc. hjerte

19'46.7" 19'52.0" 19'54.7" 19'57.4" 20'00.0"

446

**2** **2**

20'02.7" 20'05.4" 20'08.0" 20'10.7" 20'13.4" 20'16.0" 42

452 "messing"

senza sord.

*mp*

20'18.7" 20'21.4" 20'24.0" 20'26.7"

458

3

20'29.4" 20'32.0" 20'34.7" 20'37.4"

462

3

20'40.0" 20'42.7" 20'45.4" 20'48.0" 43

466 etc.

3 3 3

(obligat ostinatkompleks)

20'50.7" 20'53.4" 20'56.0" 21'01.4" 21'04.0"

470

3 3 3 3

20'58.7" 21'01.4" 21'04.0"

473

3 *mf*

21'06.7" 21'09.4" 21'12.0"

476 **44**

21'14.7" 21'17.4" 21'20.0"

479

21'22.7" 21'25.4" 21'28.0" 21'30.7" 21'33.4"

482

21'36.0" 21'38.7" 21'41.4" 21'44.0" 21'46.7"

**45**

21'49.4" 21'52.0" 21'54.7"

492

21'57.4" 22'00.0" 22'02.7" 22'05.4"

495 **46** 2

22'10.7" 22'13.4" 22'16.0" 22'18.7"

500

22'21.4" 22'24.0" 22'26.7" 22'29.4" 22'32.0" 22'34.7"

47

22'37.4" 22'40.0" 22'42.7" 22'45.4"

510

22'48.0" 22'50.7" 22'53.4" 22'56.0" 22'58.7"

48

23'01.4" 23'04.0" 23'06.7" 23'09.4" 23'12.0"

519

23'14.7" 23'17.4" 23'20.0" 23'38.7"

524

49 50

7 6

23'54.7" 23'57.4" 24'00.0" 24'02.7"

539

24'05.4" 24'08.0" 24'10.7" 24'13.4" 24'16.0"

543

24'18.7" 24'21.4" 24'24.0" 24'26.7" 24'29.4"

548

24'34.7" Distorted pno 24'37.4" 24'40.0" 24'42.7" 24'45.4" 24'48.0"

554

24'53.4" 24'56.0" 24'58.7" 25'01.4" 25'04.0"

561

25'06.7" 25'09.4" 25'12.0" 25'14.7" 25'17.4" 25'20.0"

566

25'22.7" 25'25.4" 25'28.0"

572 54

mf

25'30.7" 25'33.4" 25'36.0"

575

25'38.7" 25'41.4" 25'44.0" 25'46.7" 25'49.4"

578 etc.

25'52.0" 25'54.7" 25'57.4" 26'00.0" 26'02.7" 26'08.0"

583 55

26'10.7" 26'13.4" 26'16.0" 26'18.7"

590 56

26'21.4" 26'24.0" 26'29.4" 26'32.0"

594 simile al fine 57

26'34.7" 26'37.4" 26'40.0" 26'42.7" 26'48.0" 26'50.7"

599 etc. 58

f



26'53.4" 26'56.0" 26'58.7"

606 etc. **2**



27'04.0" 27'06.7" 27'09.4" 27'12.0" 27'14.7"

610



27'17.4" 27'20.0" 27'22.7" 27'25.4" 27'36.0"

**59** **4**

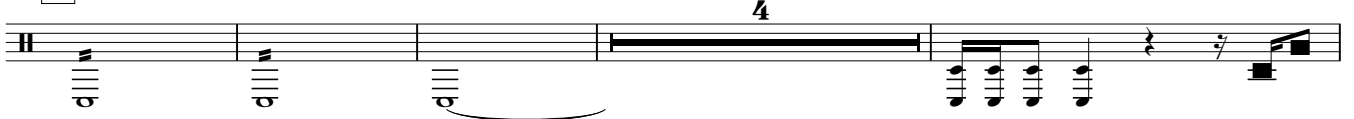

27'38.7" 27'41.4"

**60**

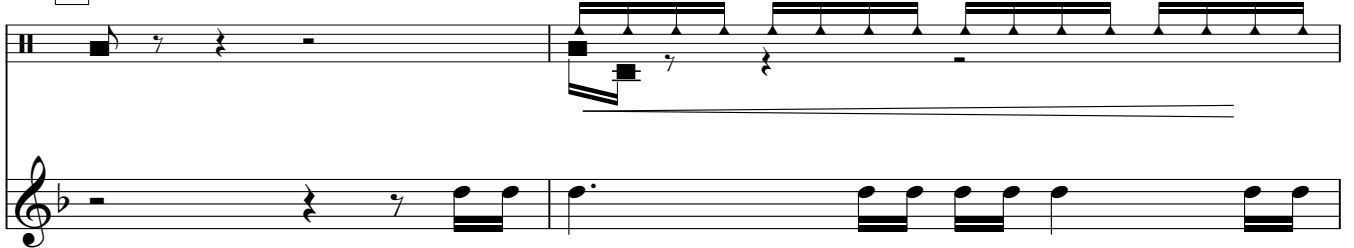

27'44.0" 27'46.7" 27'49.4" 27'57.4"

625 **61**

**3** **3**

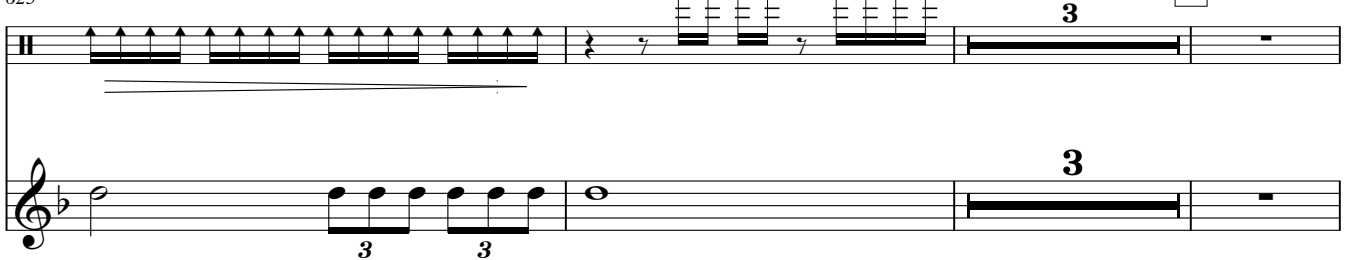

28'00.0" 28'02.7" 28'05.4" 28'08.0"

631

3 3 3

28'10.7" 28'13.4" 28'16.0" 28'18.7"

635

28'21.4" 28'24.0" 28'26.7" 28'29.4"

639

62

28'32.0" 28'34.7" 28'37.4" 28'40.0"

643

28'42.7" 28'45.4" 28'48.0" 28'50.7" 28'53.4"

647

63

28'56.0" 28'58.7" 29'01.4" 29'04.0" 29'06.7"

652

64

29'09.4" 29'12.0" 29'14.7" 29'17.4" 29'20.0" **64**

657

29'22.7" 29'25.4" 29'28.0" 29'30.7" simile...

662

29'33.4" 29'36.0" 29'38.7" 29'41.4" 29'44.0" **65**

666

29'46.7" 29'49.4" 29'52.0" 29'54.7"

671

29'57.4" 30'00.0" 30'02.7" 30'05.4" **CRESCENDO AL Forte Fortissimo**

675

30'08.0" 30'10.7" **66** 30'13.4"

679

30'16.0" 30'18.7" 30'21.4"

682

This system contains measures 682, 683, and 684. The top staff is a piano accompaniment with chords and some melodic fragments. The bottom staff is a trumpet line in B-flat major, featuring eighth-note patterns with accents and slurs.

30'24.0" 30'26.7"

67

This system contains measures 685 and 686. The piano accompaniment continues with chords. The trumpet line features a consistent eighth-note pattern with accents and slurs.

30'29.4" 30'32.0"

687

This system contains measures 687 and 688. The piano accompaniment continues with chords. The trumpet line features a consistent eighth-note pattern with accents and slurs.

30'34.7" 30'37.4"

689

This system contains measures 689 and 690. The piano accompaniment continues with chords. The trumpet line features a consistent eighth-note pattern with accents and slurs.

30'40.0" 30'42.7"

68

This system contains measures 691 and 692. The piano accompaniment continues with chords. The trumpet line features a consistent eighth-note pattern with accents and slurs.

30'45.4" 30'48.0"

693

This system contains measures 693 and 694. The piano accompaniment continues with chords. The trumpet line features a consistent eighth-note pattern with accents and slurs.

30'50.7" 30'53.4"

695

Musical score for measures 695-700. The top staff shows a complex rhythmic pattern with many beamed notes. The bottom staff shows a melodic line with eighth notes and rests.

30'56.0" 30'58.7"

697

Musical score for measures 697-702. The top staff shows a complex rhythmic pattern with many beamed notes. The bottom staff shows a melodic line with eighth notes and rests.

31'01.4" 31'04.0"

699

Musical score for measures 699-704. The top staff shows a complex rhythmic pattern with many beamed notes. The bottom staff shows a melodic line with eighth notes and rests.